

Digital Mass Flow Controller

Model F4Q

Overview

This device is a high-performance digital mass flow controller with advanced functions for the general industrial market. It features high accuracy, high-speed response, and a wide control range.

Features

- High-speed controllability
High-speed response of 300 ms (typ.)* (700 ms for F4Q0050(J,K)/0200)
* When control begins from the fully closed state or when the setting is changed during control, the controlled flow rate reaches the set value $\pm 2\%$ within 300 ms.
- Low differential pressure operation
This device can be used even at a low differential pressures. (The minimum operating differential pressure differs depending on the model)
- Wide control range
Provides a wide control range of 1–100 % full scale (FS).
- A lineup of products suited to customers' applications
The lineup consists of integrated-display models and separate-display models.
With a separate-display model, a special 2 m cable (included) can be used for remote display and operation of the controller.
- Ease of use
The product runs on 24 V DC from a single general-purpose power supply. In addition, the power supply circuit and I/O circuit inside the device are isolated.
When multiple F4Qs are driven through analog input/output using a programmable logic controller (PLC) or the like, even if the analog module channels on the PLC side are not isolated, a common power supply can be used to power the units.
Even without using an individual power supply for each device, there is no need for concern regarding effects from one circuit on adjacent ones.
In addition, for easy use in a laboratory, a convenient AC adapter (optional) is available.



- Ease of setup
This device can be set up easily by connecting it and a PC with a general-purpose USB 2.0 cable and using the dedicated PC loader software.
There is no need for an external power supply during setup because power is supplied from the PC through the USB cable.
(Note that USB power cannot be used for control or for powering the display.)
- Changeable display orientation
The orientation of the display unit can be changed according to the gas flow direction to make it easy to read.
- Better design
A large indicator for better visibility and design.
The use of an LCD on the display makes it easy to check settings and numerical values.
- A variety of functions
A variety of functions are included as standard features.

Specifications

■ F4Q9200/9500/0002

Item		F4Q9200	F4Q9500	F4Q0002
Valve type		Proportional solenoid valve		
Valve operation		Normally closed (N.C.) when not powered		
Standard full scale flow rate (air/nitrogen)*1		200 mL/min	0.5 L/min	2 L/min
Standard compatible gas type*2	Fluoroelastomer gasket	Air/nitrogen, oxygen, argon, carbon dioxide, fuel gas 13A (45 MJ/m ³), 100 % methane, 100 % propane, 100 % butane		
	EPDM gasket	Air/nitrogen, argon, carbon dioxide		

Item		F4Q9200	F4Q9500	F4Q0002
Control	Control range	1 to 100 % FS		
	Response time* ³	0.3 s (typ.) to the setting ± 2 % FS (when control begins with the valve fully closed, or when the setting is changed during control)		
	Accuracy (under standard conditions. Q: flow rate)* ⁴	± 1 % SP ($40 \leq Q \leq 100$ %) ± 0.4 % FS ($1 \leq Q < 40$ %)	± 1 % SP ($15 \leq Q \leq 100$ %) ± 0.15 % FS ($1 \leq Q < 15$ %)	
	Repeatability (Q: Flow rate)	± 0.25 % SP ($40 \leq Q \leq 100$ %) ± 0.1 % FS ($1 \leq Q < 40$ %)	± 0.25 % SP ($15 \leq Q \leq 100$ %) ± 0.0375 % FS ($1 \leq Q < 15$ %)	
	Effect of temperature (Q: Flow rate)* ³ * ⁵	± 0.1 % SP/ $^{\circ}$ C ($40 \leq Q \leq 100$ %) ± 0.015 % FS/ $^{\circ}$ C ($1 \leq Q < 40$ %)	± 0.1 % SP/ $^{\circ}$ C ($15 \leq Q \leq 100$ %) ± 0.015 % FS/ $^{\circ}$ C ($1 \leq Q < 15$ %)	
	Effect of pressure* ⁵	0.3 % FS / 100 kPa		
Pressure	Standard differential pressure	200 kPa (inlet pressure: 200 kPa (gauge); outlet pressure: 0 kPa (gauge))		
	Operating differential pressure* ⁶ * ⁷	50 to 300 kPa	5 to 300 kPa	50 to 300 kPa
	Allowable inlet pressure	0.5 MPa (gauge)		
	Pressure resistance	1 MPa (gauge)		
Operating conditions	Ambient temperature	-10 to + 60 $^{\circ}$ C		
	Ambient humidity	10 to 90 % RH (without condensation)		
	Vibration condition	No vibration		
Transport/storage conditions	Ambient temperature	-20 to +70 $^{\circ}$ C		
	Drop	0.8 m (when packed)		
	Vibration resistance	4.9 m/s ² (10 to 60 Hz, in the X, Y, and Z directions for two hours when mounted with the bracket)		
	Shock resistance	X direction: 147 m/s ² , Y and Z directions: 490 m/s ² (three times in each direction when mounted with the bracket. See ■ External dimensions (for directions))		
External leakage	1×10^{-8} Pa·m ³ /s (He) (not including O-ring permeability)			
Flow rate setting	Method	(1) Use of the keys, (2) External analog input, (3) Loader communication, (4) RS-485 communication (3-wire system)		
Analog input	Input type	0-5 V DC, 1-5 V DC, 4-20 mA (switchable)		
	Input impedance	1 M Ω ± 10 % for DC voltage input, 250 Ω ± 10 % for current input		
Analog output	Output type	Instantaneous flow rate (PV) output or flow rate set point (SP) output (switchable)		
	Output scale	0 to full-scale flow rate (scale can be changed)		
	Output type	0-5 V DC, 1-5 V DC, 4-20 mA (switchable)		
	Maximum output	7 V DC or less / 28 mA or less		
	Accuracy	± 0.3 % FS (overall output accuracy: indication accuracy ± 0.3 % FS)		
	External load resistance	250 k Ω min. for voltage output, 300 Ω max. for current output		
Digital output	Number of outputs	3		
	Output rating	External power supply: 30 V DC max., maximum load current: 30 mA max. (Nch open drain non-isolated output, when power off: open contacts)		
	Totalization pulse width	20-100 ms (when totalizer pulse output is selected, output at multiples of 20 ms)		
	Totalization pulse weight	1-1,000,000 mL/pulse	2-1,000,000 mL/pulse	10-1,000,000 mL/pulse
Digital input	Number of inputs	3		
	Required circuit type	Non-voltage contacts or open collector		
	Terminal voltage with contacts OFF	5 ± 0.5 V		
	Terminal current with contacts ON	Approx. 0.5 mA (current to contacts)		
	Allowable ON contact resistance	250 Ω max.		
	Allowable OFF contact resistance	100 k Ω min.		
	Allowable ON residual voltage	1.0 V max. (with open collector)		
	Allowable OFF leakage current	100 μ A max. (with open collector)		
Communication	Method* ⁸	(1) USB 2.0 (2) RS-485 communication (3-wire system, CPL or Modbus RTU)		
	Transfer speed selection	4800, 9600, 19200, 38400 bps (with RS-485 communication)		
Power	Rating	24 V DC, current consumption: 300 mA max.		
	Allowable supply voltage range	21.6-26.4 V DC (ripple: 5 % max.)		
	Isolation	The power supply circuit and I/O circuit are isolated.		
Connection method* ⁹	Rc 1/4, 1/4 Swagelok, 1/4 VCR, 9/16-18 UNF			
Main gas-contacting materials* ¹⁰	Fluoroelastomer gasket	SUS316, SUS316L, K-M35F, Teflon, fluoroelastomer		
	EPDM gasket	SUS316, SUS316L, K-M35F, Teflon, EPDM		
Mounting orientation* ¹¹	Horizontally (the top panel should not face downward) or vertically			
Weight	About 1.2 kg			
Protective structure	IP40* ¹²			
Standards compliance* ¹⁵	EN 61326-1, EN 61326-2-3			

■ F4Q0005/0020

Item		F4Q0005	F4Q0020
Valve type		Proportional solenoid valve	
Valve operation		Normally closed (N.C.) when not powered	
Standard full scale flow rate (air/nitrogen)*1		5 L/min	20 L/min
Standard compatible gas type*2	Fluoroelastomer gasket	Air/nitrogen, oxygen, argon, carbon dioxide, fuel gas 13A (45 MJ/m ³), 100 % methane, 100 % propane, 100 % butane	
	EPDM gasket	Air/nitrogen, argon, carbon dioxide	
Control	Control range	1 to 100 % FS	
	Response time*3	0.3 s (typ.) to the setting ±2 % FS (when control begins with the valve fully closed, or when the setting is changed during control)	
	Accuracy (under standard conditions. Q: flow rate)*4	±1 % SP (15 ≤ Q ≤ 100 %) ±0.15 % FS (1 ≤ Q < 15 %)	
	Repeatability (Q: Flow rate)	±0.25 % SP (15 ≤ Q ≤ 100 %) ±0.0375 % FS (1 ≤ Q < 15 %)	
	Effect of temperature (Q: Flow rate)*3 *5	±0.1 % SP/°C (15 ≤ Q ≤ 100 %) ±0.015 % FS/°C (1 ≤ Q < 15 %)	
	Effect of pressure*5	0.3 % FS / 100 kPa	
Pressure	Standard differential pressure	200 kPa (inlet pressure: 200 kPa (gauge); outlet pressure: 0 kPa (gauge))	
	Operating differential pressure*6 *7	5 to 300 kPa	50 to 300 kPa
	Allowable inlet pressure	0.5 MPa (gauge)	
	Pressure resistance	1 MPa (gauge)	
Operating conditions	Ambient temperature	−10 to + 60 °C	
	Ambient humidity	10 to 90 % RH (without condensation)	
	Vibration condition	No vibration	
Transport/storage conditions	Ambient temperature	−20 to +70 °C	
	Drop	0.8 m (when packed)	
	Vibration resistance	4.9 m/s ² (10 to 60 Hz, in the X, Y, and Z directions for two hours when mounted with the bracket)	
	Shock resistance	X direction: 147 m/s ² , Y and Z directions: 490 m/s ² (three times in each direction when mounted with the bracket. See ■ External dimensions (for directions))	
External leakage		1×10 ^{−8} Pa·m ³ /s (He) (not including O-ring permeability)	
Flow rate setting	Method	(1) Use of the keys, (2) External analog input, (3) Loader communication, (4) RS-485 communication (3-wire system)	
Analog input	Input type	0–5 V DC, 1–5 V DC, 4–20 mA (switchable)	
	Input impedance	1 MΩ ±10 % for DC voltage input, 250 Ω ±10 % for current input	
Analog output	Output type	Instantaneous flow rate (PV) output or flow rate set point (SP) output (switchable)	
	Output scale	0 to full-scale flow rate (scale can be changed)	
	Output type	0–5 V DC, 1–5 V DC, 4–20 mA (switchable)	
	Maximum output	7 V DC or less / 28 mA or less	
	Accuracy	±0.3 % FS (overall output accuracy: indication accuracy ±0.3 % FS)	
	External load resistance	250 kΩ min. for voltage output, 300 Ω max. for current output	
Digital output	Number of outputs	3	
	Output rating	External power supply: 30 V DC max., maximum load current: 30 mA max. (Nch open drain non-isolated output, when power off: open contacts)	
	Totalization pulse width	20–100 ms (when totalizer pulse output is selected, output at multiples of 20 ms)	
	Totalization pulse weight	20–1,000,000 mL/pulse	100–1,000,000 mL/pulse
Digital input	Number of inputs	3	
	Required circuit type	Non-voltage contacts or open collector	
	Terminal voltage with contacts OFF	5 ±0.5 V	
	Terminal current with contacts ON	Approx. 0.5 mA (current to contacts)	
	Allowable ON contact resistance	250 Ω max.	
	Allowable OFF contact resistance	100 kΩ min.	
	Allowable ON residual voltage	1.0 V max. (with open collector)	
	Allowable OFF leakage current	100 μA max. (with open collector)	
Communication	Method*8	(1) USB 2.0 (2) RS-485 communication (3-wire system, CPL or Modbus RTU)	
	Transfer speed selection	4800, 9600, 19200, 38400 bps (with RS-485 communication)	
Power	Rating	24 V DC, current consumption: 300 mA max.	
	Allowable supply voltage range	21.6–26.4 V DC (ripple: 5 % max.)	
	Isolation	The power supply circuit and I/O circuit are isolated.	
Connection method*9		Rc ¼, ¼ Swagelok, ¼ VCR, 9/16–18 UNF	
Main gas-contacting materials*10	Fluoroelastomer gasket	SUS316, SUS316L, K-M35F, Teflon, fluoroelastomer	
	EPDM gasket	SUS316, SUS316L, K-M35F, Teflon, EPDM	
Mounting orientation*11		Horizontally (the top panel should not face downward) or vertically	

Item	F4Q0005	F4Q0020
Weight	About 1.2 kg	
Protective structure	IP40*12	
Standards compliance*15	EN 61326-1, EN 61326-2-3	

■ F4Q0050 (B,C)

Item	F4Q0050 (B, C)	
Valve type	Proportional solenoid valve	
Valve operation	Normally closed (N.C.) when not powered	
Standard full scale flow rate (air/nitrogen)*1	50 L/min	
Standard compatible gas type*2	Fluoroelastomer gasket	Air/nitrogen, oxygen, argon, carbon dioxide, fuel gas 13A (45 MJ/m ³), 100 % methane, 100 % propane, 100 % butane
	EPDM gasket	Air/nitrogen, argon, carbon dioxide
Control	Control range	1 to 100 % FS
	Response time*3	0.3 s (typ.) to the setting ± 2 % FS (when control begins with the valve fully closed, or when the setting is changed during control)
	Accuracy (under standard conditions. Q: flow rate)*4	± 1 % SP ($15 \leq Q \leq 100$ %) ± 0.15 % FS ($1 \leq Q < 15$ %)
	Repeatability (Q: Flow rate)	± 0.25 % SP ($15 \leq Q \leq 100$ %) ± 0.0375 % FS ($1 \leq Q < 15$ %)
	Effect of temperature (Q: Flow rate)*3 *5	± 0.1 % SP/ $^{\circ}$ C ($15 \leq Q \leq 100$ %) ± 0.015 % FS/ $^{\circ}$ C ($1 \leq Q < 15$ %)
	Effect of pressure*5	0.3 % FS / 100 kPa
Pressure	Standard differential pressure	200 kPa (inlet pressure: 200 kPa (gauge); outlet pressure: 0 kPa (gauge))
	Operating differential pressure*6 *7	100 to 300 kPa
	Allowable inlet pressure	0.5 MPa (gauge)
	Pressure resistance	1 MPa (gauge)
Operating conditions	Ambient temperature	-10 to + 60 $^{\circ}$ C
	Ambient humidity	10 to 90 % RH (without condensation)
	Vibration condition	No vibration
Transport/storage conditions	Ambient temperature	-20 to +70 $^{\circ}$ C
	Drop	0.8 m (when packed)
	Vibration resistance	4.9 m/s ² (10 to 60 Hz, in the X, Y, and Z directions for two hours when mounted with the bracket)
	Shock resistance	X direction: 147 m/s ² , Y and Z directions: 490 m/s ² (three times in each direction when mounted with the bracket. See ■ External dimensions (for directions))
External leakage	1×10^{-8} Pa·m ³ /s (He) (not including O-ring permeability)	
Flow rate setting	Method	(1) Use of the keys, (2) External analog input, (3) Loader communication, (4) RS-485 communication (3-wire system)
Analog input	Input type	0-5 V DC, 1-5 V DC, 4-20 mA (switchable)
	Input impedance	1 M Ω ± 10 % for DC voltage input, 250 Ω ± 10 % for current input
Analog output	Output type	Instantaneous flow rate (PV) output or flow rate set point (SP) output (switchable)
	Output scale	0 to full-scale flow rate (scale can be changed)
	Output type	0-5 V DC, 1-5 V DC, 4-20 mA (switchable)
	Maximum output	7 V DC or less / 28 mA or less
	Accuracy	± 0.3 % FS (overall output accuracy: indication accuracy ± 0.3 % FS)
	External load resistance	250 k Ω min. for voltage output, 300 Ω max. for current output
Digital output	Number of outputs	3
	Output rating	External power supply: 30 V DC max., maximum load current: 30 mA max.
	Totalization pulse width	20-100 ms (when totalizer pulse output is selected, output at multiples of 20 ms)
	Totalization pulse weight	200-1,000,000 mL/pulse
Digital input	Number of inputs	3
	Required circuit type	Non-voltage contacts or open collector
	Terminal voltage with contacts OFF	5 ± 0.5 V
	Terminal current with contacts ON	Approx. 0.5 mA (current to contacts)
	Allowable ON contact resistance	250 Ω max.
	Allowable OFF contact resistance	100 k Ω min.
	Allowable ON residual voltage	1.0 V max. (with open collector)
Allowable OFF leakage current	100 μ A max. (with open collector)	
Communication	Method*8	(1) USB 2.0 (2) RS-485 communication (3-wire system, CPL or Modbus RTU)
	Transfer speed selection	4800, 9600, 19200, 38400 bps (with RS-485 communication)
Power	Rating	24 V DC, current consumption: 300 mA max.
	Allowable supply voltage range	21.6-26.4 V DC (ripple: 5 % max.)
	Isolation	The power supply circuit and I/O circuit are isolated.

Item		F4Q0050 (B, C)
Connection method*9		Rc ¼, ¼ Swagelok, ¼ VCR, 9/16–18 UNF
Main gas-contacting materials*10	Fluoroelastomer gasket	SUS316, SUS316L, K-M35F, Teflon, fluoroelastomer
	EPDM gasket	SUS316, SUS316L, K-M35F, Teflon, EPDM
Mounting orientation*11		Horizontally (the top panel should not face downward) or vertically
Weight		About 1.2 kg
Protective structure		IP40*12
Standards compliance*15		EN 61326-1, EN 61326-2-3

■ F4Q0050(J,K)

Item		F4Q0050(J,K)
Valve type		Pilot valve
Valve operation		Normally closed (N.C.) when not powered
Standard full scale flow rate (air/nitrogen)*1		50 L/min
Standard compatible gas type*2	Fluoroelastomer gasket	Air/nitrogen, oxygen, argon, carbon dioxide, fuel gas 13A (45 MJ/m ³), 100 % methane, 100 % propane, 100 % butane
	EPDM gasket	–
Control	Control range	1 to 100 % FS
	Response time*3	0.7 s (typ.) to the setting ±2 % FS (when control begins with the valve fully closed, or when the setting is changed during control)
	Accuracy (under standard conditions. Q: flow rate)*4	±1.5 % SP (30 ≤ Q ≤ 100 %) ±0.45 % FS (0 ≤ Q < 30 %)
	Repeatability (Q: Flow rate)	±0.375 % SP (30 ≤ Q ≤ 100 %) ±0.113 % FS (0 ≤ Q < 30 %)
	Effect of temperature (Q: Flow rate)*3 *5	±0.15 % SP/°C (30 ≤ Q ≤ 100 %) ±0.045 % FS (0 ≤ Q < 30 %)
	Effect of pressure*5	0.3 % FS / 100 kPa
Pressure	Standard differential pressure	50 kPa (inlet pressure: 50 kPa (gauge); outlet pressure: 0 kPa (gauge))
	Operating differential pressure*6 *7	10 to 100 kPa
	Allowable inlet pressure	0.5 MPa (gauge)
	Pressure resistance	1 MPa (gauge)
Operating conditions	Ambient temperature	–10 to + 60 °C
	Ambient humidity	10 to 90 % RH (without condensation)
	Vibration condition	No vibration
Transport/storage conditions	Ambient temperature	–20 to +70 °C
	Drop	0.8 m (when packed)
	Vibration resistance	4.9 m/s ² (10 to 60 Hz, in the X, Y, and Z directions for two hours when mounted with the bracket)
	Shock resistance	X direction: 147 m/s ² , Y and Z directions: 490 m/s ² (three times in each direction when mounted with the bracket. See ■ External dimensions (for directions))
External leakage		1×10 ⁻⁸ Pa·m ³ /s (He) (not including O-ring permeability)
Flow rate setting	Method	(1) Use of the keys, (2) External analog input, (3) Loader communication, (4) RS-485 communication (3-wire system)
Analog input	Input type	0–5 V DC, 1–5 V DC, 4–20 mA (switchable)
	Input impedance	1 MΩ ±10 % for DC voltage input, 250 Ω ±10 % for current input
Analog output	Output type	Instantaneous flow rate (PV) output or flow rate set point (SP) output (switchable)
	Output scale	0 to full-scale flow rate (scale can be changed)
	Output type	0–5 V DC, 1–5 V DC, 4–20 mA (switchable)
	Maximum output	7 V DC or less / 28 mA or less
	Accuracy	±0.3 % FS (overall output accuracy: indication accuracy ±0.3 % FS)
	External load resistance	250 kΩ min. for voltage output, 300 Ω max. for current output
Digital output	Number of outputs	3
	Output rating	External power supply: 30 V DC max., maximum load current: 30 mA max.
	Totalization pulse width	20–100 ms (when totalizer pulse output is selected, output at multiples of 20 ms)
	Totalization pulse weight	200–1,000,000 mL/pulse
Digital input	Number of inputs	3
	Required circuit type	Non-voltage contacts or open collector
	Terminal voltage with contacts OFF	5 ±0.5 V
	Terminal current with contacts ON	Approx. 0.5 mA (current to contacts)
	Allowable ON contact resistance	250 Ω max.
	Allowable OFF contact resistance	100 kΩ min.
	Allowable ON residual voltage	1.0 V max. (with open collector)
	Allowable OFF leakage current	100 μA max. (with open collector)

Item		F4Q0050(J,K)
Communication	Method*8	(1) USB 2.0 (2) RS-485 communication (3-wire system, CPL or Modbus RTU)
	Transfer speed selection	4800, 9600, 19200, 38400 bps (with RS-485 communication)
Power	Rating	24 V DC, current consumption: 400 mA max.
	Allowable supply voltage range	21.6–26.4 V DC (ripple: 5 % max.)
	Isolation	The power supply circuit and I/O circuit are isolated.
Connection method*9		Rc ½, ½ Swagelok, ½ VCR, 3/4–16 UNF
Main gas-contacting materials*10	Fluoroelastomer gasket	SUS316, SUS316L, K-M35F, Teflon, fluoroelastomer
	EPDM gasket	–
Mounting orientation*11		Horizontally (the top panel should not face downward) or vertically
Weight		About 3.1 kg
Protective structure		IP40*13
Standards compliance*15		EN 61326-1, EN 61326-2-3

■ F4Q0100/0200

Item		F4Q0100	F4Q0200
Valve type		Pilot valve	
Valve operation		Normally closed (N.C.) when not powered	
Standard full scale flow rate (air/nitrogen)*1		100 L/min	200 L/min
Standard compatible gas type*2	Fluoroelastomer gasket	Air/nitrogen, oxygen, argon, carbon dioxide, fuel gas 13A (45 MJ/m ³), 100 % methane, 100 % propane, 100 % butane	
	EPDM gasket	–	Air/nitrogen, argon, carbon dioxide
Control	Control range	1 to 100 % FS	
	Response time*3	0.3 s (typ.) to the setting ±2 % FS	0.7 s (typ.) to the setting ±2 % FS
		(when control begins with the valve fully closed, or when the setting is changed during control)	
	Accuracy (under standard conditions. Q: flow rate)*4	±1.5 % SP (60 ≤ Q ≤ 100 %) ±0.9 % FS (0 ≤ Q < 60 %)	±1 % SP (30 ≤ Q ≤ 100 %) ±0.3 % FS (0 ≤ Q < 30 %)
	Repeatability (Q: Flow rate)	±0.375 % SP (60 ≤ Q ≤ 100 %) ±0.225 % FS (0 ≤ Q < 60 %)	±0.25 % SP (30 ≤ Q ≤ 100 %) ±0.075 % FS (0 ≤ Q < 30 %)
Effect of temperature (Q: Flow rate)*3 *5		±0.15 % SP/°C (60 ≤ Q ≤ 100 %) ±0.09 % FS/°C (0 ≤ Q < 60 %)	±0.1 % SP/°C (30 % ≤ Q ≤ 100 %) ±0.05 % FS/°C (0 % ≤ Q < 30 %)
	Effect of pressure*5	0.3 % FS / 100 kPa	
Pressure	Standard differential pressure	200 kPa (inlet pressure: 200 kPa (gauge); outlet pressure: 0 kPa (gauge))	
	Operating differential pressure*6 *7	200 to 400 kPa	100 to 300 kPa
	Allowable inlet pressure	0.5 MPa (gauge)	
	Pressure resistance	1 MPa (gauge)	
Operating conditions	Ambient temperature	–10 to + 60 °C	–10 to + 60 °C (Condition: power voltage = 24 V)*14
	Ambient humidity	10 to 90 % RH (without condensation)	
	Vibration condition	No vibration	
Transport/storage conditions	Ambient temperature	–20 to +70 °C	
	Drop	0.8 m (when packed)	
	Vibration resistance	4.9 m/s ² (10 to 60 Hz, in the X, Y, and Z directions for two hours when mounted with the bracket)	
	Shock resistance	X direction: 147 m/s ² , Y and Z directions: 490 m/s ² (three times in each direction when mounted with the bracket. See ■ External dimensions (for directions))	
External leakage		1×10 ⁻⁸ Pa·m ³ /s (He) (not including O-ring permeability)	
Flow rate setting	Method	(1) Use of the keys, (2) External analog input, (3) Loader communication, (4) RS-485 communication (3-wire system)	
Analog input	Input type	0–5 V DC, 1–5 V DC, 4–20 mA (switchable)	
	Input impedance	1 MΩ ±10 % for DC voltage input, 250 Ω ±10 % for current input	
Analog output	Output type	Instantaneous flow rate (PV) output or flow rate set point (SP) output (switchable)	
	Output scale	0 to full-scale flow rate (scale can be changed)	
	Output type	0–5 V DC, 1–5 V DC, 4–20 mA (switchable)	
	Maximum output	7 V DC or less / 28 mA or less	
	Accuracy	±0.3 % FS (overall output accuracy: indication accuracy ±0.3 % FS)	
External load resistance	250 kΩ min. for voltage output, 300 Ω max. for current output		
Digital output	Number of outputs	3	
	Output rating	External power supply: 30 V DC max., maximum load current: 30 mA max. (Nch open drain non-isolated output, when power off: open contacts)	
	Totalization pulse width	20–100 ms (when totalizer pulse output is selected, output at multiples of 20 ms)	
	Totalization pulse weight	500–1,000,000 mL/pulse	1,000–1,000,000 mL/pulse

Item		F4Q0100	F4Q0200
Digital input	Number of inputs	3	
	Required circuit type	Non-voltage contacts or open collector	
	Terminal voltage with contacts OFF	5 ±0.5 V	
	Terminal current with contacts ON	Approx. 0.5 mA (current to contacts)	
	Allowable ON contact resistance	250 Ω max.	
	Allowable OFF contact resistance	100 kΩ min.	
	Allowable ON residual voltage	1.0 V max. (with open collector)	
Communication	Method*8	(1) USB 2.0 (2) RS-485 communication (3-wire system, CPL or Modbus RTU)	
	Transfer speed selection	4800, 9600, 19200, 38400 bps (with RS-485 communication)	
Power	Rating	24 V DC, current consumption: 300 mA max.	
	Allowable supply voltage range	21.6–26.4 V DC (ripple: 5 % max.)	
	Isolation	The power supply circuit and I/O circuit are isolated.	
Connection method*9		Rc ¼, ⅜ Swagelok, ½ VCR, 9/16–18 UNF	Rc ½, ⅜ Swagelok, ½ VCR, 3/4–16 UNF
Main gas-contacting materials*10	Fluoroelastomer gasket	SUS316, SUS316L, K-M35F, Teflon, fluoroelastomer	
	EPDM gasket	–	SUS316, SUS316L, K-M35F, Teflon, EPDM
Mounting orientation*11		Horizontally (the top panel should not face downward) or vertically	
Weight		About 1.2 kg	About 3.1 kg
Protective structure		IP40*12	IP40*13
Standards compliance*15		EN 61326-1, EN 61326-2-3	

- *1. mL/min and L/min indicate the volumetric flow rate per minute converted to conditions of 0 °C and 101.325 kPa (1 atm). The controllable flow rate range varies depending on the gas type. Refer to the gas type and control range.
- *2. The gas must be dry and not contain corrosive components (chlorine, sulfur, acid, etc.). Also, it must be clean, without dust or oil mist.
- *3. Value at standard differential pressure.
- *4. Instrument error under standard conditions according to our equipment.
- Fluid: air ● Inlet pressure: standard differential pressure ±15 kPa (gauge) ● Outlet pressure: atmospheric pressure
 - Ambient temperature: 23 ±2 °C ● Gas temperature: same as ambient temperature ● Operational mode: control mode
 - Vibration/pulsation: none
 - Warm-up time: leave at ambient temperature for 2 hours or more, and leave for 30 minutes or more after turning on the power
 - Device orientation: horizontal with the display facing upward
 - Straight pipe length: any (F4Q9200/9500/0002/0005/0020/0050), 25 mm (F4Q0100), 50 mm (F4Q0200)
- *5. Fluid: value is for air.
- *6. Operation is possible below the minimum operating differential pressure, but the controllable flow rate range narrows.
- *7. If a gas other than air or nitrogen is used and if the ambient temperature is high, the gas may not flow at the maximum flow rate even when this device is operating within the operating differential pressure range. Increase the supply pressure or lower the ambient temperature.
- *8. USB 2.0 is used when connecting to Azbil's PC loader software. This device supports micro USB Type-B (2 m max.) connection.
- *9. Before connecting pipes with Swagelok or VCR fittings, check the instructions in the manual provided by the manufacturer of the fitting.
- *10. The gas-contacting parts are degreased.
- *11. In the case of vertical mounting, an error occurs in measurements. The error can be corrected with device settings.
- *12. Main unit: only when the connector is connected. Separate display unit: only the front of the display
- *13. Main unit: only when the connector is connected. The location where the valve cable enters the unit is not included. Separate display unit: only the front of the display
- *14. The maximum operating ambient temperature of the F4Q0200 differs depending on the power voltage. See the graph below. If the operating conditions are outside the shaded area, the control range may be narrower.

F4Q0200: Relationship between power voltage and maximum ambient temperature

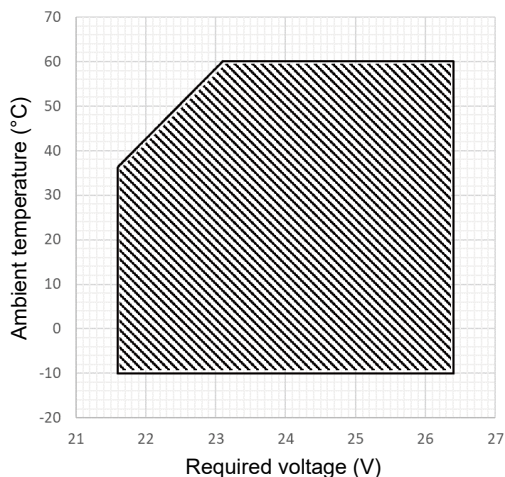

- *15. During EMC testing, fluctuations equivalent to ±10 % FS in the reading and output may occur.

Functions

Function		Overview
Display-related	Display orientation setup	The screen display and key orientation can be changed to match the device's orientation.
	Multi-information display	Various kinds of information, including process data such as instantaneous flow rate and device status, can be displayed.
	Key lock function	Key operation on the display panel of this device can be limited to prevent operation errors and as a security measure.
	Flow rate display change (units and digits after the decimal point)	The unit of measurement and the number of digits after the decimal point for instantaneous flow rate data display can be changed.
	Totalized flow volume display change (unit)	The unit of measurement and the number of digits after the decimal point for totalized flow rate data display can be changed.
	Automatic display-off function	This function turns off the LCD if the keys on the display panel are not used for a certain amount of time.
	PV display filter time constant setting	The displayed PV (instantaneous flow rate) can be filtered.
	User tag specification	Any character string can be displayed at the bottom of the main screen on the display of this device.
Flow rate control	Flow rate setting	The flow rate can be changed using the operation keys, digital input, analog input, or communication.
	Direct setup function	When the flow rate setting is changed using the keys, the entered value is applied immediately as the control SP.
	Valve operation mode switching	The valve operation mode can be switched between control mode, fully closed mode, and fully open mode.
	SP limit	The lower and upper limits of the flow rate setting range can be freely set (to prevent incorrect setting due to operator error).
	Control response setup	Control can be optimized.
	PID constants	Any PID constant can be set.
	Flow rate OK judgment	This function determines whether the control flow rate is within the set value \pm the allowable range.
	Flow rate deviation event	Event output can be set for upper and lower deviation of instantaneous flow rate from the flow rate set point. The operating mode can be set to change automatically if an event occurs.
	SP ramp control	The change rate per second (gradient) of the flow rate set point can be kept constant when control starts and when the flow rate setting is changed.
Measurement conditions, flow rate correction	Setting of standard temperature for flow rate display	You can select the standard temperature used when converting from the measured mass flow rate to volumetric flow rate.
	Gas type selection	The gas type can be selected from the standard compatible gases.
	PV filter	The output PV can be smoothed.
	PV fluctuation control function when fully closed	The PV filter can be expanded after a delay when the flow rate set point is set to zero or when the valve changes to fully closed mode.
	Low flow cutoff	The flow rate below the specified threshold is regarded as zero.
	Flow rate zero point adjustment	Drift in the zero point of the sensor can be adjusted.
	Device orientation & pressure compensation	Compensation can be made for sensor drift due to the orientation of the pipe on which the device is mounted or due to the effect of pressure.
	Filter application during response	Whether to apply the PV filter to the output PV during control response can be selected.
	Full-scale flow rate setting for the gas type set by the user	The control range of the gas type set by the user can be changed freely.
	Multipoint flow rate correction	Linear compensation function for up to 10 points. The control flow rate can be fine-tuned to the reference device.
Analog input/output	Analog input/output function	The analog input/output type can be selected from 0–5 V, 1–5 V, and 4–20 mA. In addition, PV output or SP output can be selected as the output item.
	Optional analog scaling	The flow rate corresponding to 100 % analog input/output (5 V or 20 mA) can be freely changed to any value.
	Analog input/output adjustment	Span adjustment and offset can be applied to the analog input and analog output.
Digital input/output	Digital input function	The device can be remotely operated by assigning functions to the three digital inputs.
	Digital output function	The device can be remotely monitored by allocating the device status, event, or other item to the three digital outputs.
Flow volume totalization	Total flow volume count pause	Flow volume totalization can be paused with digital input.
	Total flow volume reset	The totalized flow volume can be reset to zero using the keys, digital input, communication, or other means.
	Totalizer pulse output	A pulse can be output every time the specified volume of flow is measured.
	Totalized flow volume event	An event can be output when the totalized flow volume reaches the specified value. In addition, the device can be automatically switched to fully closed mode if the event occurs.

Function		Overview
Diagnostic function	Self-diagnostic function	Problems such as circuit failure, parameter error, or flow rate control error are detected and output as device status information.
	Diagnostic information	Information such as total operating time, full-close count, and abnormal device status since the product was shipped are internally recorded.
	Fail-safe function	The operating mode or analog output can be set to change automatically if an error occurs.
Communication function	RS-485	Data can be exchanged with host devices (master stations) such as a PC or a PLC via RS-485 communication. For details, see Digital Mass Flow Controller Model F4Q User's Manual for RS-485 Communication Functions (CP-SP-1458E).
Loader	Device setup and monitoring	A simplified engineering software tool (loader) that runs on a PC can be used for a variety of purposes related to settings, monitoring, etc.

Standard gases: gas types and control ranges

The controllable flow rate range varies depending on the gas type. For details, see the following table.

Depending on the ambient temperature and differential pressure, gases may not flow at the maximum flow rate.

Increase the supply pressure or lower the ambient temperature.

Gas type \ Model No.	F4Q9200	F4Q9500	F4Q0002
	Control flow rate range [mL/min (normal)]	Control flow rate range [L/min (normal)]	Control flow rate range [L/min (normal)]
Air/nitrogen	2–200	0.005–0.500	0.02–2
Oxygen	2–200	0.005–0.500	0.02–2
Argon	2–200	0.005–0.500	0.02–2
Carbon dioxide	1.2–120	0.003–0.300	0.012–1.2
Fuel gas 13A (45 MJ/m ³)	2–200	0.005–0.500	0.02–2
100 % methane	2–200	0.005–0.500	0.02–2
100 % propane	0.6–60	0.002–0.160	0.006–0.6
100 % butane	0.5–50	0.001–0.120	0.004–0.4

Gas type \ Model No.	F4Q0005	F4Q0020	F4Q0050 (B,C)
	Control flow rate range [L/min (normal)]	Control flow rate range [L/min (normal)]	Control flow rate range [L/min (normal)]
Air/nitrogen	0.05–5	0.2–20	0.5–50
Oxygen	0.05–5	0.2–20	0.5–50
Argon	0.05–5	0.2–20	0.5–50
Carbon dioxide	0.03–3	0.12–12	0.3–30
Fuel gas 13A (45 MJ/m ³)	0.05–5	0.2–20	0.5–50
100 % methane	0.05–5	0.2–20	0.5–50
100 % propane	0.016–1.6	0.06–6	0.16–16
100 % butane	0.012–1.2	0.04–4	0.1–10

Gas type \ Model No.	F4Q0050(J,K)	F4Q0100	F4Q0200
	Control flow rate range [L/min (normal)]	Control flow rate range [L/min (normal)]	Control flow rate range [L/min (normal)]
Air/nitrogen	0.5–50	1–100	2–200
Oxygen	0.5–50	1–100	2–200
Argon	0.5–50	1–100	2–200
Carbon dioxide	0.3–30	0.8–80	1.2–120
Fuel gas 13A (45 MJ/m ³)	0.5–50	0.8–80	2–200
100 % methane	0.5–50	0.9–90	2–200
100 % propane	0.16–16	0.32–32	0.6–60
100 % butane	0.12–12	0.2–20	0.4–40

Other than standard gases: main gas types, C.F.s, and control ranges

	Model F4Q9200		Model F4Q9500		Model F4Q0002	
	C.F.	Control flow rate range [mL/min (normal)]	C.F.	Control flow rate range [L/min (normal)]	C.F.	Control flow rate range [L/min (normal)]
Acetylene	0.560	2–120	0.560	0.005–0.300	0.610	0.02–1.2
Ammonia	0.760	3–160	0.760	0.007–0.400	0.770	0.03–1.6
Helium	6.812	14–640	6.750	0.034–3.300	5.001	0.10–6.4

	Model F4Q0005		Model F4Q0020		Model F4Q0050(B,C)	
	C.F.	Control flow rate range [L/min (normal)]	C.F.	Control flow rate range [L/min (normal)]	C.F.	Control flow rate range [L/min (normal)]
Acetylene	0.560	0.05–3	0.610	0.2–12	0.610	0.5–30
Ammonia	0.760	0.07–4	0.770	0.3–16	0.770	0.7–40
Helium	7.129	0.36–35	5.027	1.0–64	4.973	2.5–160

	Model F4Q0050(J,K)		Model F4Q0100		Model F4Q0200	
	C.F.	Control flow rate range [L/min (normal)]	C.F.	Control flow rate range [L/min (normal)]	C.F.	Control flow rate range [L/min (normal)]
Acetylene	–	–	–	–	0.610	1–120
Ammonia	–	–	–	–	0.770	2–160
Helium	7.082	3.5–350	4.637	4.2–320	4.935	9.7–640

• How to use

Before using this device, set the conversion factor (C.F.) for the gas using the following procedure.

- (1) Change function setting C18 (gas type selection 1) to “0” (gas type set by the user).
- (2) Referring to the tables above, change parameter setting P10 (user-set gas conversion factor (C.F.) in accordance with the type of gas and model number.

Note 1: The conversion factors given in the tables above are estimated values, so their accuracy for the gas you actually use is not guaranteed and a large error may occur. Therefore, please check the accuracy before using the product.

Note 2: When setting the C.F., set a flow rate set point (SP) that is within the control range. Note that, if an SP outside the control range is set, the flow rate cannot be controlled correctly.

Note 3: To find out whether other gases or mixed gases can be used and their C.F., please contact the azbil Group.

Note 4: Even if the C.F. is specified, the full-scale flow rate set in this device will not change automatically. Use the loader to change the full-scale flow rate setting for a user-set gas. When the product is shipped, the full-scale flow rate for air and nitrogen is set for the user-set gas. (Example: 0.5 L/min for the F4Q9500)

Note 5: Depending on the ambient temperature and differential pressure, gases may not flow at the maximum flow rate. Increase the supply pressure or lower the ambient temperature.

Relationship between differential pressure and flow rate when the valve is open fully (for air)

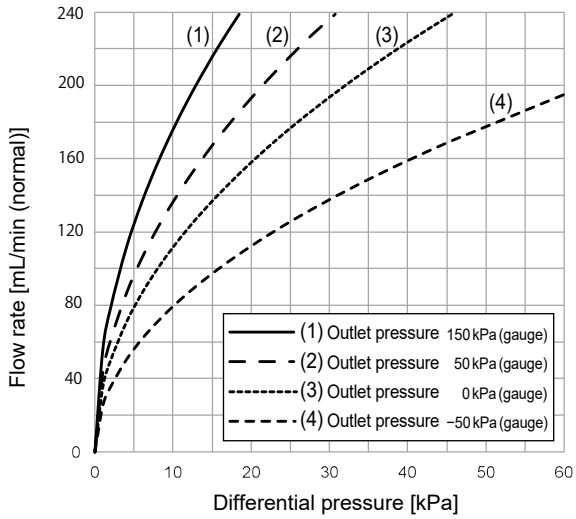

F4Q9200

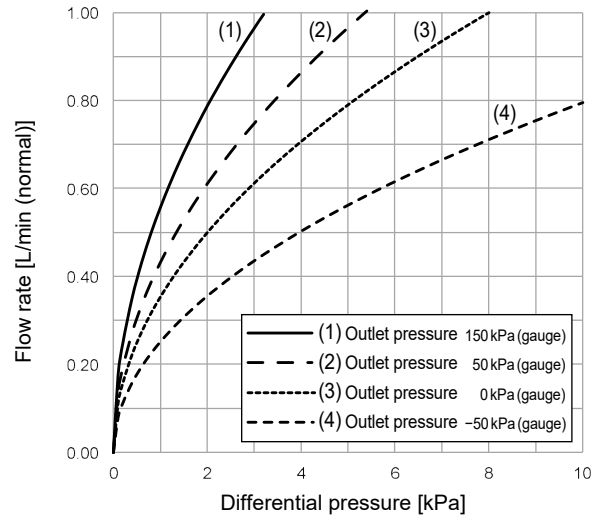

F4Q9500

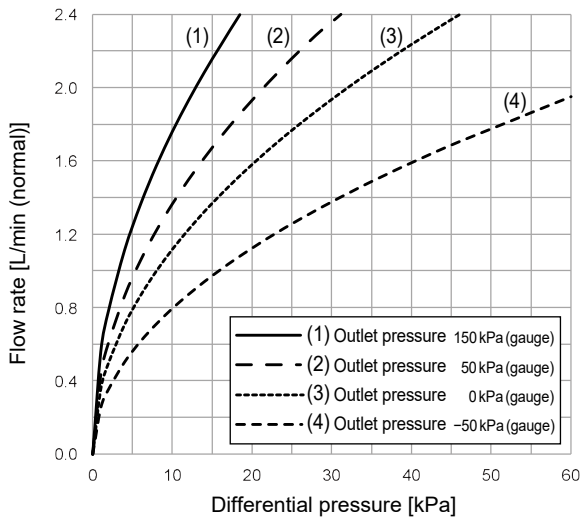

F4Q0002

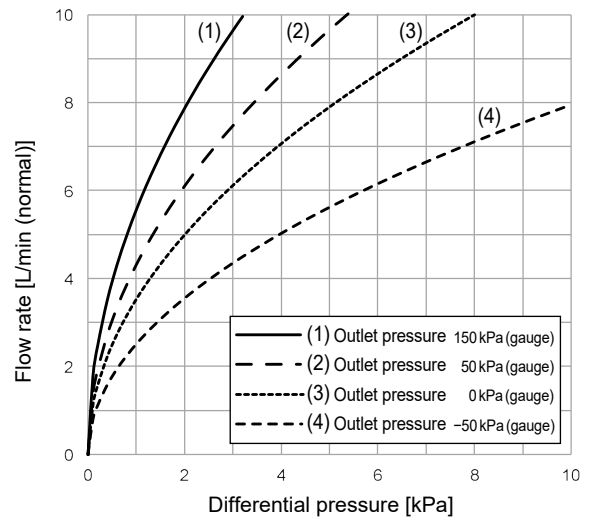

F4Q0005

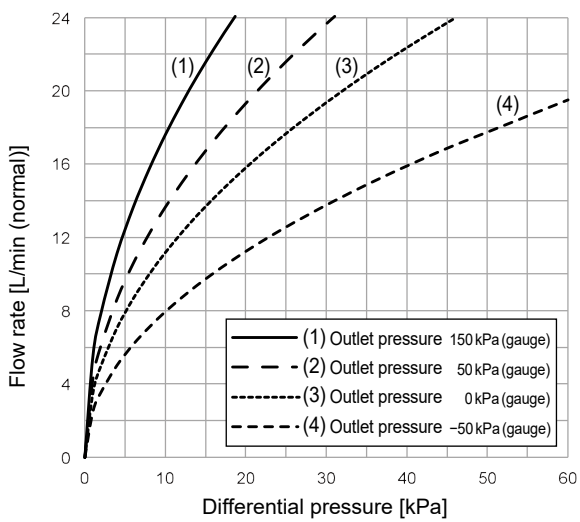

F4Q0020

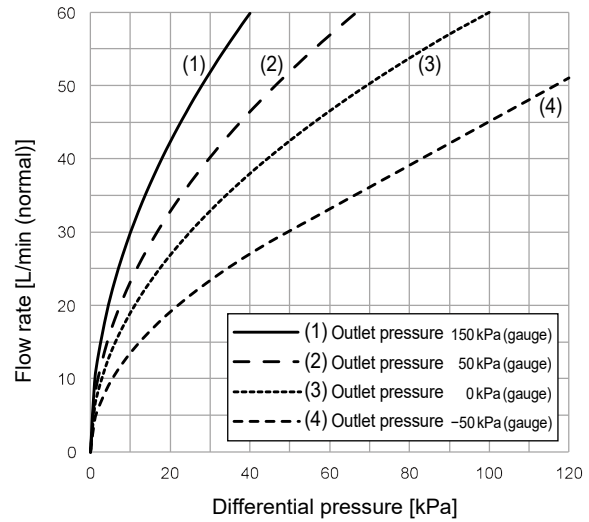

F4Q0050 (B,C)

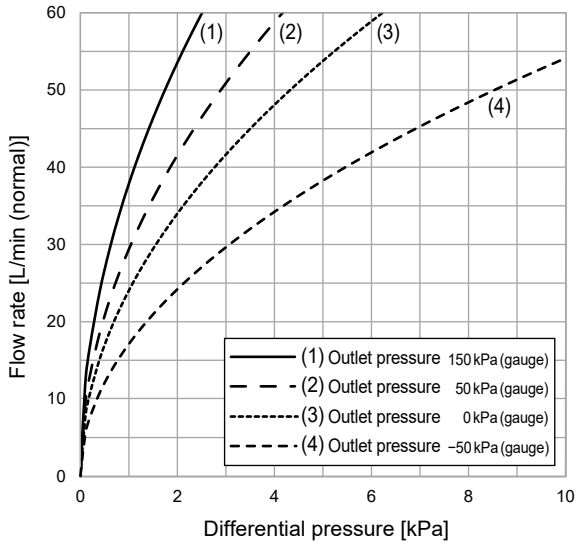

F4Q0050 (J,K)

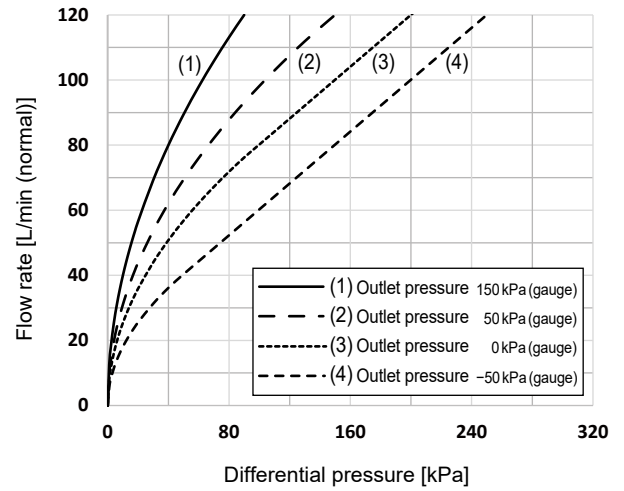

F4Q0100

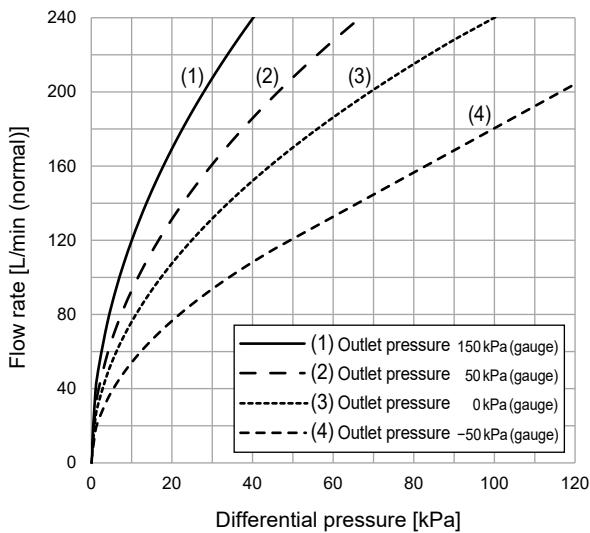

F4Q0200

! Handling Precautions

- For an output pressure not shown on the graphs above, calculate the flow rate with one of the formulas below.

(1) If $P2/P1 > 0.53$, $Q = C1\sqrt{(P1-P2) P2}$

(2) $P2/P1 \leq 0.53$, $Q = C2 \cdot P1$

P1: Inlet absolute pressure [kPa (abs)]

P2: Outlet absolute pressure [kPa (abs)]

(Absolute pressure = gauge pressure + 101.3 kPa)

Q: Flow rate [L/min (normal)]

C1, C2: Constant values according to the model

F4Q9200: C1 = 0.003513, C2 = 0.001753

F4Q9500: C1 = 0.03513, C2 = 0.01753

F4Q0002: C1 = 0.03513, C2 = 0.01753

F4Q0005: C1 = 0.3513, C2 = 0.1753

F4Q0020: C1 = 0.3513, C2 = 0.1753

F4Q0050(B,C): C1 = 0.5971, C2 = 0.2981

F4Q0050(J,K): C1 = 2.389, C2 = 1.192

F4Q0100: C1 = 0.7979, C2 = 0.3983

F4Q0200: C1 = 2.389, C2 = 1.192

- For a gas other than air, use the formula below for conversion.

Flow rate = air flow rate $\div \sqrt{\text{specific gravity of the desired gas}}$

Specific gravity of standard compatible gases (air = 1.0)

Gas type	Specific gravity
Oxygen	1.11
Argon	1.38
Carbon dioxide	1.53
Fuel gas 13 A	0.64
Methane	0.56
Propane	1.56
Butane	2.08

Terminal connections

• Connector pin layout

Connector model No.: DF02R020NA4

Manufacturer: Japan Aviation Electronics Industry, Ltd.

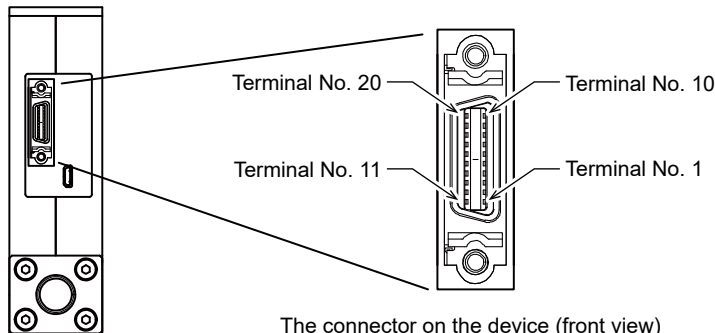

The connector on the device (front view)

• Compatible connectors (all made by Japan Aviation Electronics Industry, Ltd.)

• Solder-type connector

Number of wires	Compatible wire	Plug	Hood				Clamp plate	Appropriate dimensions (reference)	
			Hood for EMI shielding	Lock spring	Straight long				
20	22–30 AWG	DF02P020F22A1	Hood for EMI shielding	Lock spring	Straight long	DF02D020A11	DF02HCLP05A	φ6.5–7.0	
							DF02HCLP02A	φ7.0–7.5	
							DF02HCLP01A	φ7.5–8.0	
							DF02HCLP10A	φ8.5–9.0	
			Hood without resin coating	Lock spring	Straight long	DF02D020A22			φ11.0–12.0

• Crimp type

Number of wires	Compatible wire	Plug	Hood				Clamp plate	Appropriate dimensions (reference)	
			Hood for EMI shielding	Lock spring	Straight long				
20	28 AWG	DF02P020G28A1	Hood for EMI shielding	Lock spring	Straight long	DF02D020A11	DF02HCLP05A	φ6.5–7.0	
							DF02HCLP02A	φ7.0–7.5	
							DF02HCLP01A	φ7.5–8.0	
							DF02HCLP10A	φ8.5–9.0	
			Hood without resin coating	Lock spring	Straight long	DF02D020A22			φ11.0–12.0

• Connector signal table

Pin No.	Signal name	Description	Notes
1	DA	RS-485 comm., DA	For the connection procedure, see Digital Mass Flow Controller Model F4Q User's Manual for RS-485 Communication Functions (CP-SP-1458E).
2	DB	RS-485 comm., DB	
3	S.GND	RS-485 comm. (-)	
4	AI	Analog input (+)	Flow rate set point (SP) input 0–5 V, 1–5 V, or 4–20 mA input
5	AO	Analog output (+)	Controlled flow rate (PV) or flow rate set point (SP) output 0–5 V, 1–5 V, or 4–20 mA output
6	A.GND	Analog signal (-)	Common ground for analog signals
7	P.GND	24 V DC (-) power	Rated 24 V DC ±10 % Connect two wires each in parallel to the power supply to reduce the voltage drop caused by wiring resistance.
8	P.GND	24 V DC (-) power	
9	P.24 V	24 V DC (+) power	
10	P.24 V	24 V DC (+) power	
11	DO1	Digital output 1 (+)	Nch open drain non-isolated output
12	DO2	Digital output 2 (+)	
13	DO3	Digital output 3 (+)	
14	D.GND	Digital signal (-)	Common ground for digital signals
15	DI1	Digital input 1 (+)	2-way (OPEN/GND) switching input
16	DI2	Digital input 2 (+)	
17	DI3	Digital input 3 (+)	
18	D.GND	Digital signal (-)	Common ground for digital signals
19	-	Not connected	
20	-	Not connected	

• **Wiring**

• Power

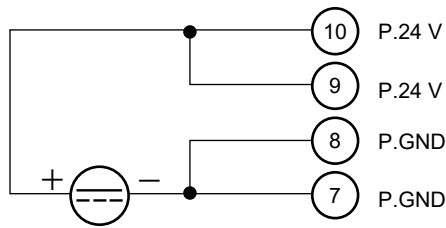

! Handling Precautions

- Connect two wires each in parallel to the power supply to reduce the voltage drop caused by wiring resistance.

• RS-485 communication

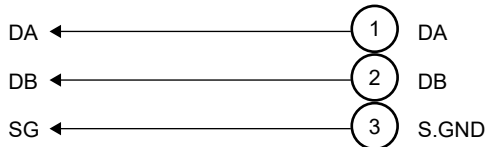

- For the connection method of RS-485 communication, see Digital Mass Flow Controller Model F4Q User's Manual for RS-485 Communication Functions (CP-SP-1458E).

• Digital output

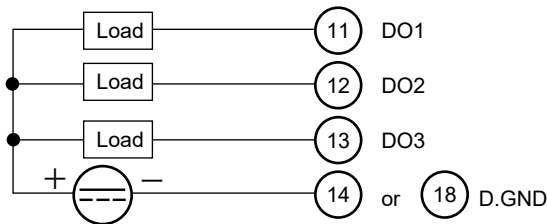

! Handling Precautions

- Be careful not to exceed the rated output of this device. In addition, when driving a relay, use a relay with a built-in diode for absorbing coil surge.

• Digital input

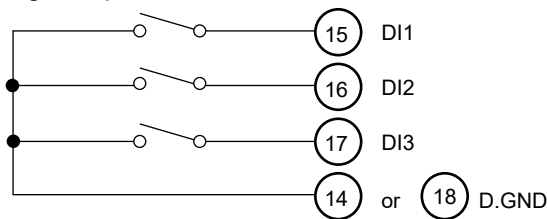

! Handling Precautions

- When switching the digital input by relay contacts, use an appropriate relay intended for microcurrent use (with gold contacts). Failure to use a relay designed for microcurrents may result in malfunction due to poor contact.

• Analog input/output

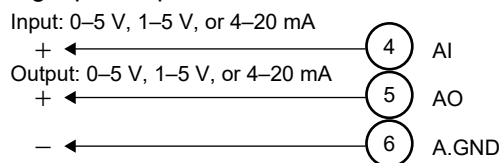

• **Wiring example**

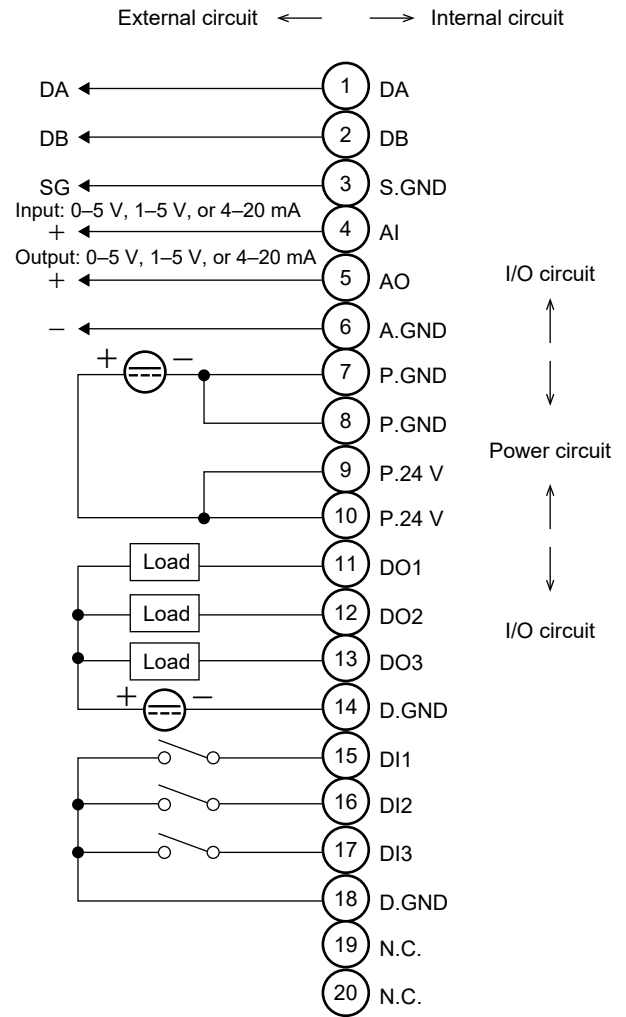

! Handling Precautions

- The power supply circuit and I/O circuit inside the device are isolated.
- Even though the A.GND, D.GND, and S.GND are connected internally, be sure to ground them separately.
- Do not input any signal to pin Nos. 19 and 20.

Model selection guide

■ Face-to-face: 90 mm (with fluoroelastomer gaskets)

Basic model No.			Standard flow rate range				Model type	Flow path material	Pipe connection	Gas type	Communication	O-ring material	Option 1	Option 2	Option 3	Code	Description
F	4	Q															
			9	2	0	0										2–200 mL/min (normal)*1	
			9	5	0	0										0.005–0.5 L/min (normal)*1	
			0	0	0	2										0.02–2 L/min (normal)*1	
			0	0	0	5										0.05–5 L/min (normal)*1	
			0	0	2	0										0.2–20 L/min (normal)*1	
			0	0	5	0										0.5–50 L/min (normal)*1	
			0	1	0	0										1–100 L/min (normal)*1	
							B									Integrated-display model	
							C									Separate-display model	
								6								SUS316	
									T							Rc ¼	
									S							¼ Swagelok fittings (Model F4Q0100 only: ¾ Swagelok)*2	
									V							¼ VCR fittings (Model F4Q0100 only: ½ VCR or the equivalent)*2	
									U							9/16-18 UNF	
										N						Air/nitrogen*3	
											1					RS-485 communication (CPL/Modbus RTU, switchable)	
												0				Fluororubber	
													0			No optional function	
													0			No optional function	
														0		0: Without inspection report	
														D		D: With inspection report	
														Y		Y: With inspection report and traceability	
															0	Product version	

*1. Control flow rate range for air and nitrogen. The notations “mL/min (normal)” and “L/min (normal)” indicate the volumetric flow rate (mL/min and L/min) converted to conditions of 0 °C and 1 atm (101.3 kPa (abs)).

*2. Before connecting pipes with Swagelok or VCR fittings, check the instructions in the manual provided by the manufacturer of the fitting.

*3. The device can be used for gases other than air and nitrogen by changing the gas type setting. The controllable flow rate range varies depending on the gas type.

■ Face-to-face: 90 mm (with EPDM gaskets)

Basic model No.			Standard flow rate range				Model type	Flow path material	Pipe connection	Gas type	Communication	O-ring material	Option 1	Option 2	Option 3	Code	Description
F	4	Q															
			9	2	0	0										2–200 mL/min (normal)*1	
			9	5	0	0										0.005–0.5 L/min (normal)*1	
			0	0	0	2										0.02–2 L/min (normal)*1	
			0	0	0	5										0.05–5 L/min (normal)*1	
			0	0	2	0										0.2–20 L/min (normal)*1	
			0	0	5	0										0.5–50 L/min (normal)*1	
							B									Integrated-display model	
							C									Separate-display model	
								6								SUS316	
									T							Rc ¼	
									S							¼ Swagelok fittings*2	
										N						Air/nitrogen*3	
											1					RS-485 communication (CPL/Modbus RTU, switchable)	
												E				EPDM*4	
													0			No optional function	
														0		No optional function	
															0	0: Without inspection report	
																D: With inspection report	
																Y: With inspection report and traceability	
																0 Product version	

- *1. Control flow rate range for air and nitrogen. The notations “mL/min (normal)” and “L/min (normal)” indicate the volumetric flow rate (mL/min and L/min) converted to conditions of 0 °C and 1 atm (101.3 kPa (abs)).
- *2. Before connecting pipes with Swagelok fittings, check the instructions in the manual provided by the manufacturer of the fitting.
- *3. The device can be used for gases other than air and nitrogen by changing the gas type setting. The controllable flow rate range varies depending on the gas type.
- *4. Only the following gases can be used with a model with the EPDM gasket specification. If this device is used for a gas that is not allowed, deterioration of the seal may result.
Compatible gases: air, nitrogen, argon, carbon dioxide, ammonia, and acetylene

■ Face-to-face: 150 mm (with fluoroelastomer gaskets)

Basic model No.			Standard flow rate range				Model type	Flow path material	Pipe connection	Gas type	Communication	O-ring material	Option 1	Option 2	Option 3	Code	Description
F	4	Q	0	0	5	0										0.5–50 L/min (normal)*1 *4	
			0	2	0	0										2–200 L/min (normal)*1	
							J									Integrated-display model	
							K									Separate-display model	
								6								SUS316	
									T							Rc ½	
									S							½ Swagelok fittings*2	
									V							½ VCR fittings or the equivalent*2	
									U							3/4-16 UNF	
										N						Air/nitrogen*3	
											1					RS-485 communication (CPL/Modbus RTU, switchable)	
												0				Fluororubber	
													0			No optional function	
														0		No optional function	
														0		0: Without inspection report	
														D		D: With inspection report	
														Y		Y: With inspection report and traceability	
															0	Product version	

*1. Control flow rate range for air and nitrogen. The notations "mL/min (normal)" and "L/min (normal)" indicate the volumetric flow rate (mL/min and L/min) converted to conditions of 0 °C and 1 atm (101.3 kPa (abs)).

*2. Before connecting pipes with Swagelok or VCR fittings, check the instructions in the manual provided by the manufacturer of the fitting.

*3. The device can be used for gases other than air and nitrogen by changing the gas type setting. The controllable flow rate range varies depending on the gas type.

*4. F4Q0050(J,K) can be used for low differential pressure application. It can control a high flow rate range with an operating differential pressure lower than F4Q0050(B,C).

■ Face-to-face: 150 mm (with EPDM gaskets)

Basic model No.			Standard flow rate range				Model type	Flow path material	Pipe connection	Gas type	Communication	O-ring material	Option 1	Option 2	Option 3	Code	Description
F	4	Q	0	2	0	0										2–200 L/min (normal)*1	
																Integrated-display model	
																Separate-display model	
							J									SUS316	
							K									Rc ½	
								6								½ Swagelok fittings*2	
									T							Air/nitrogen*3	
									S							RS-485 communication (CPL/Modbus RTU, switchable)	
										N						EPDM*4	
											1					No optional function	
												E				No optional function	
													0			0: Without inspection report	
														0		D: With inspection report	
															Y	Y: With inspection report and traceability	
																0	Product version

*1. Control flow rate range for air and nitrogen. The notations “mL/min (normal)” and “L/min (normal)” indicate the volumetric flow rate (mL/min and L/min) converted to conditions of 0 °C and 1 atm (101.3 kPa (abs)).

*2. Before connecting pipes with Swagelok fittings, check the instructions in the manual provided by the manufacturer of the fitting.

*3. The device can be used for gases other than air and nitrogen by changing the gas type setting. The controllable flow rate range varies depending on the gas type.

*4. Only the following gases can be used with a model with the EPDM gasket specification. If this device is used for a gas that is not allowed, deterioration of the seal may result.

Compatible gases: air, nitrogen, argon, carbon dioxide, ammonia, and acetylene

External dimensions

■ Model F4Q9200/9500/0002/0005/0020/0050(B,C)/0100

- Integrated-display model

(Unit: mm)

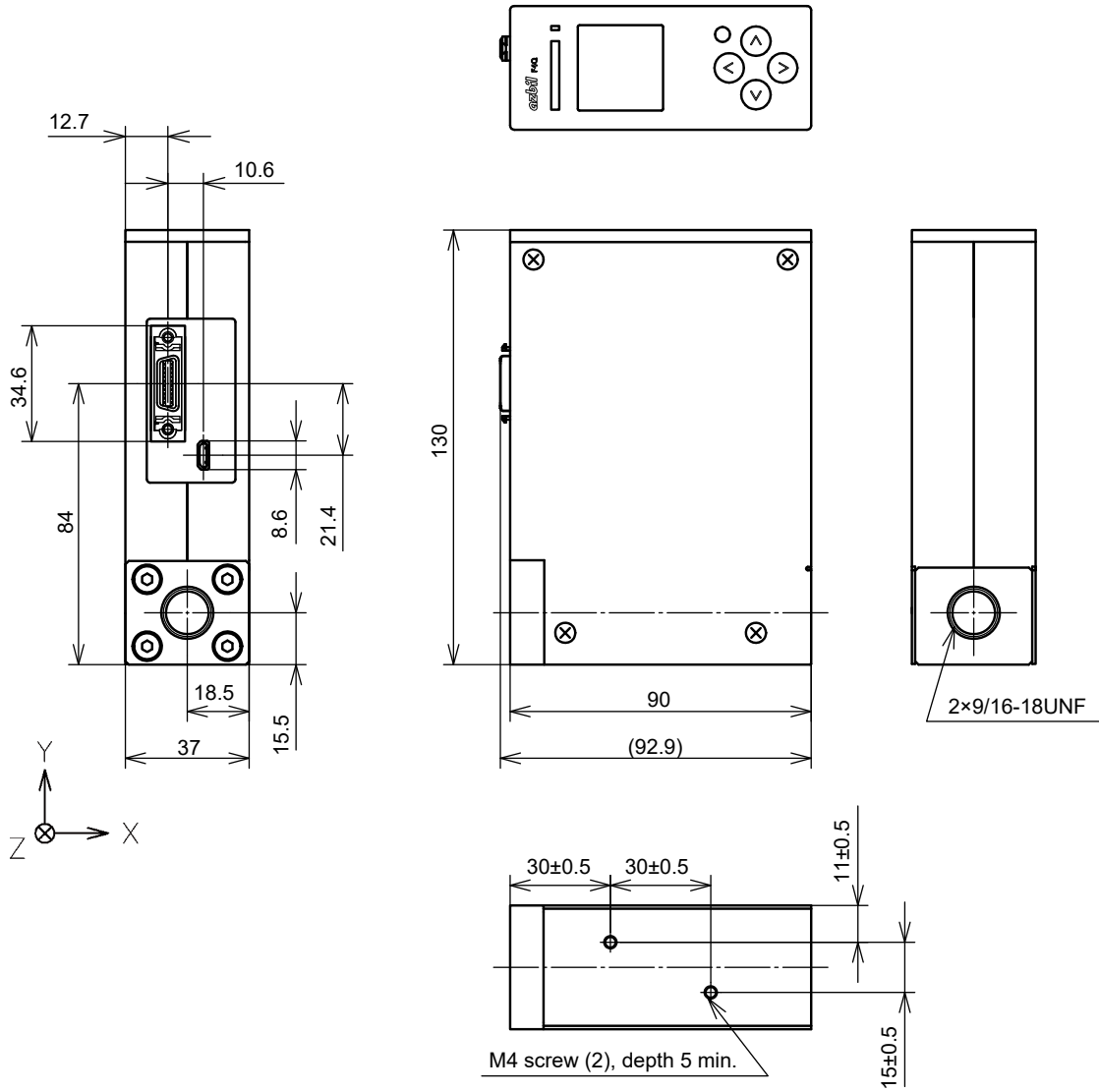

• Separate-display model

(Unit: mm)

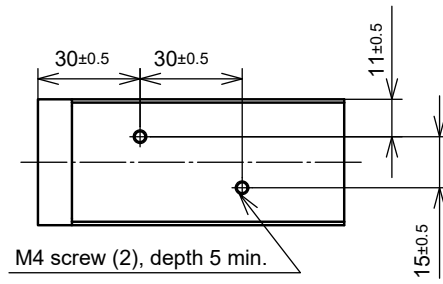
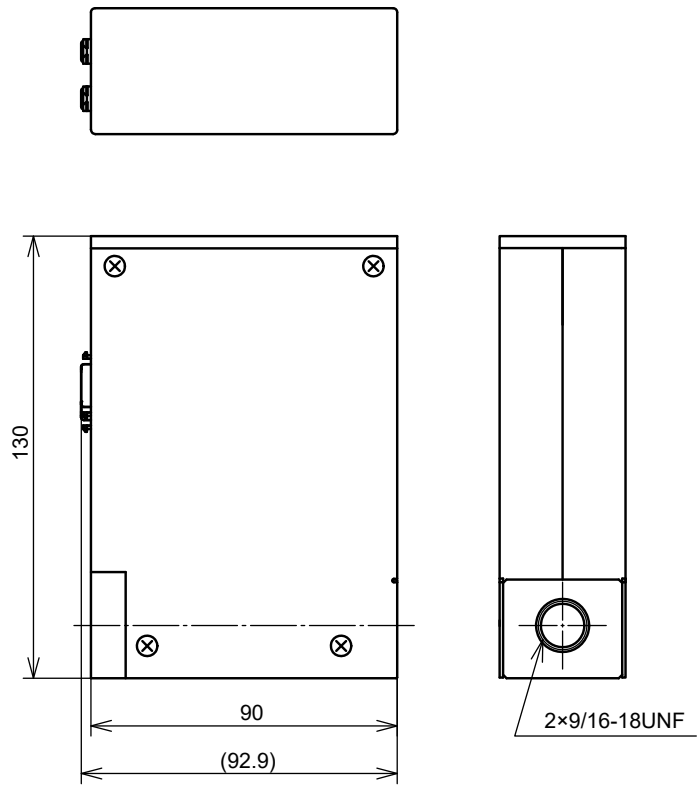
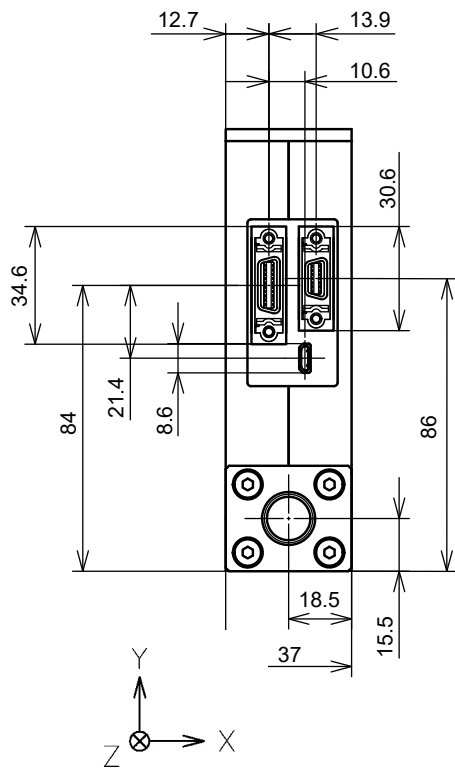

• Face-to-face length of fittings

(Unit: mm)

F4Q ___ B_T _____

F4Q ___ C_T _____

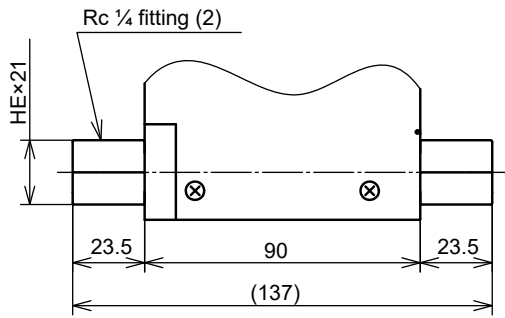

Rc 1/4 connection type

F4Q ___ B_V_0 _____

F4Q ___ C_V_0 _____

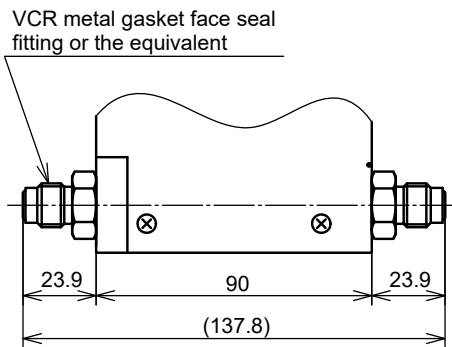

1/4 VCR connection type

F4Q0100B_T _____

F4Q0100C_T _____

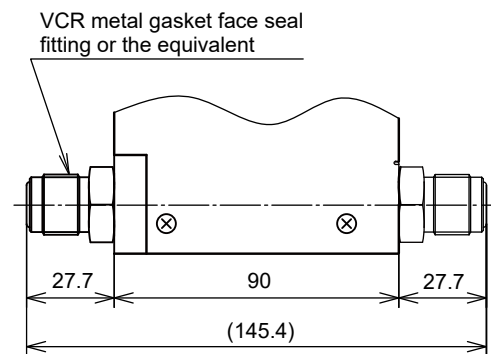

1/2 VCR connection type

F4Q ___ B_S _____

F4Q ___ C_S _____

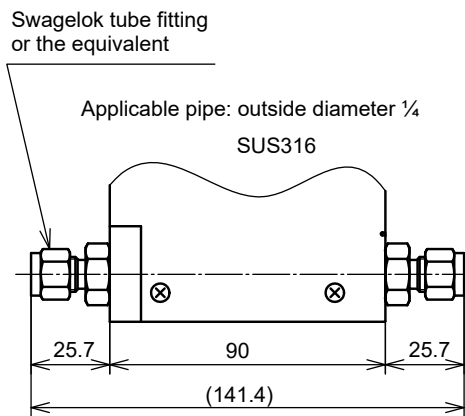

1/4 Swagelok connection type

F4Q0100B_S _____

F4Q0100C_S _____

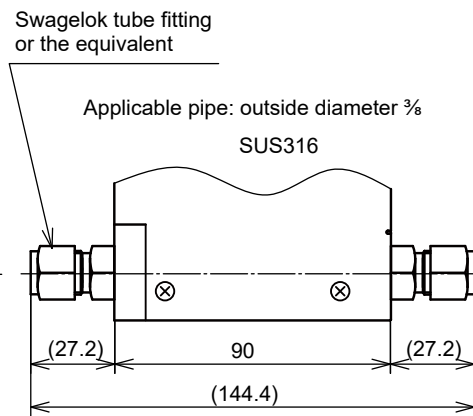

3/8 Swagelok connection type

Model F4Q0050(J,K)/0200

- Integrated-display model

(Unit: mm)

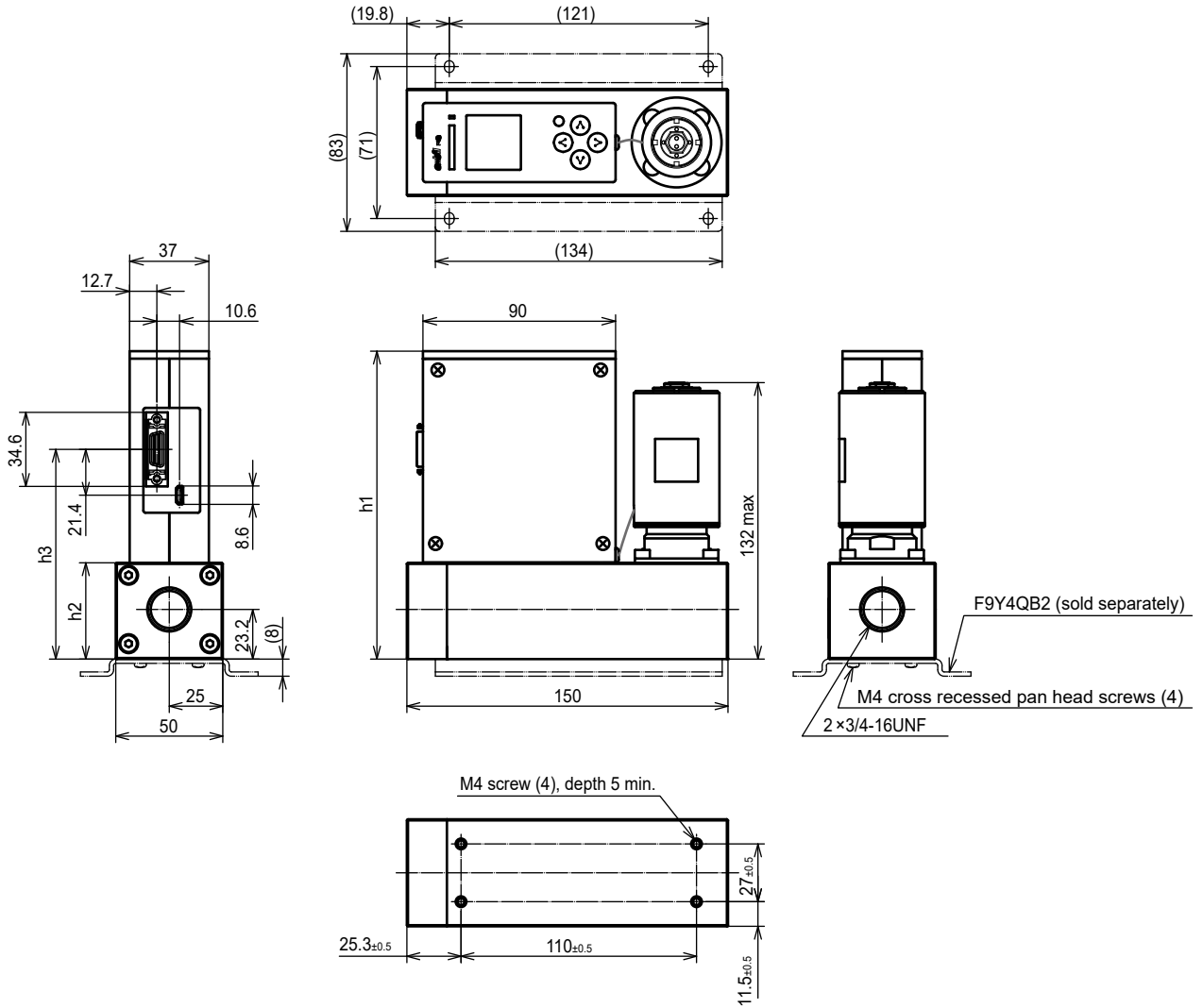

h1-4 size

	h1	h2	h3	h4
F4Q0050J,K/F4Q0200J,K	143.9	45	98	100

• Separate-display model

(Unit: mm)

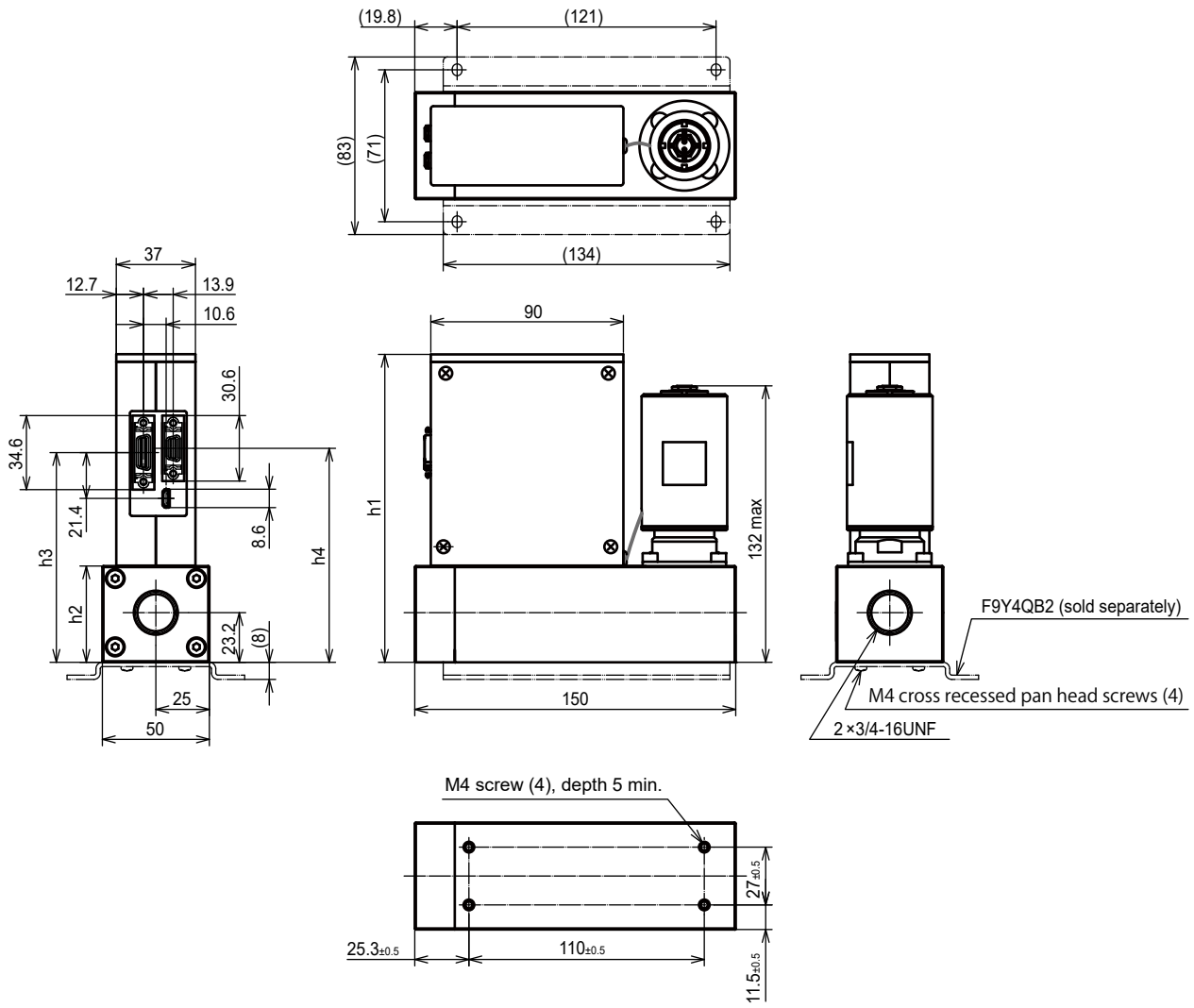

h1-4 size

	h1	h2	h3	h4
F4Q0050J,K/F4Q0200J,K	143.9	45	98	100

• Face-to-face length of fittings

(Unit: mm)

F4Q___J_R_____

F4Q___K_R_____

F4Q___J_V_0_____

F4Q___K_V_0_____

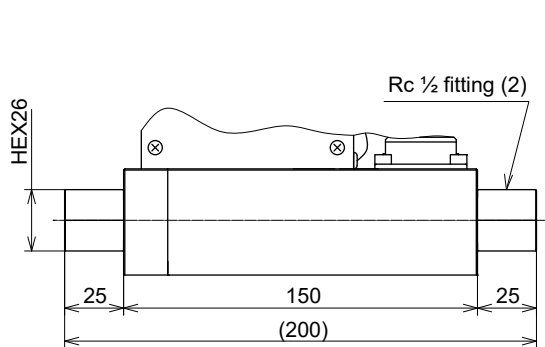

Rc 1/2 connection type

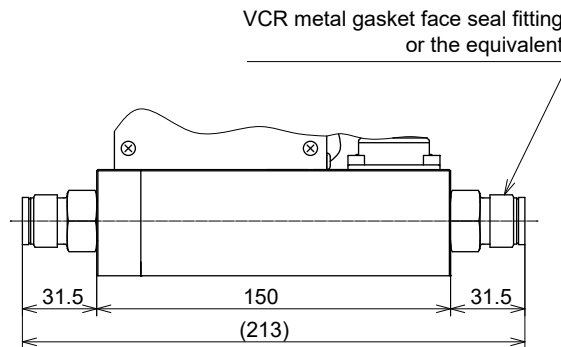

1/2 VCR connection type

F4Q___J_S_____

F4Q___K_S_____

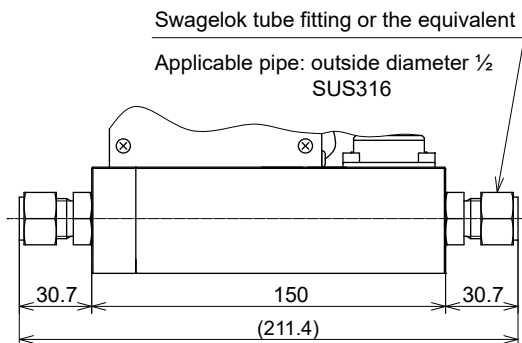

1/2 Swagelok connection type

■ Separate display unit

(Unit: mm)

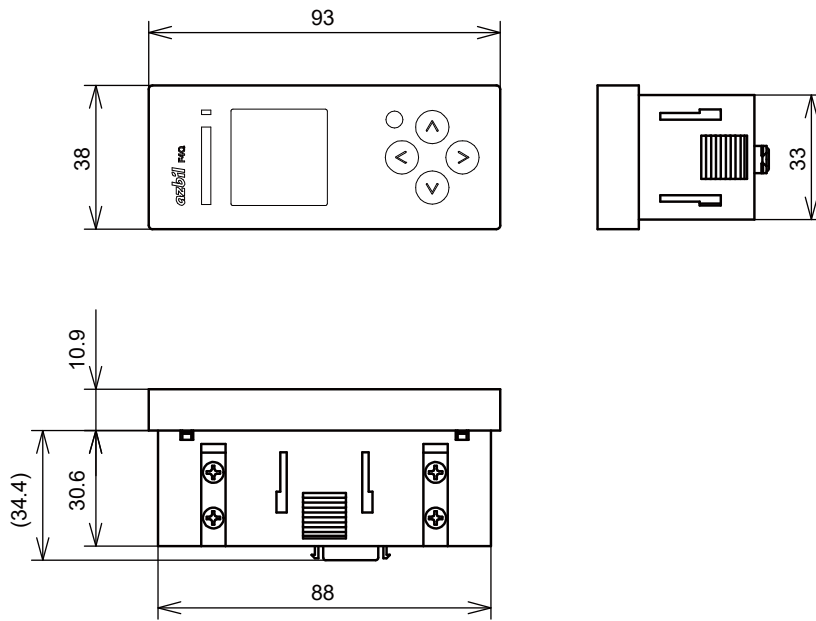

■ Cable for separate display unit

(Unit: mm)

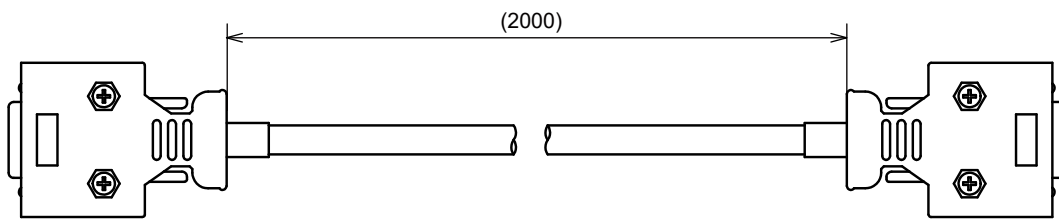

■ **Dimensions of optional cables**

- Model F9Y4QHP2, model F9Y4QHP5

(Unit: mm)

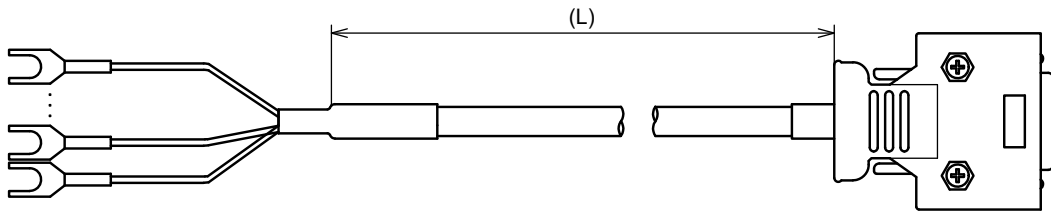

Model No.	L [mm]
F9Y4QHP2	2000
F9Y4QHP5	5000

- Model F9Y4A1

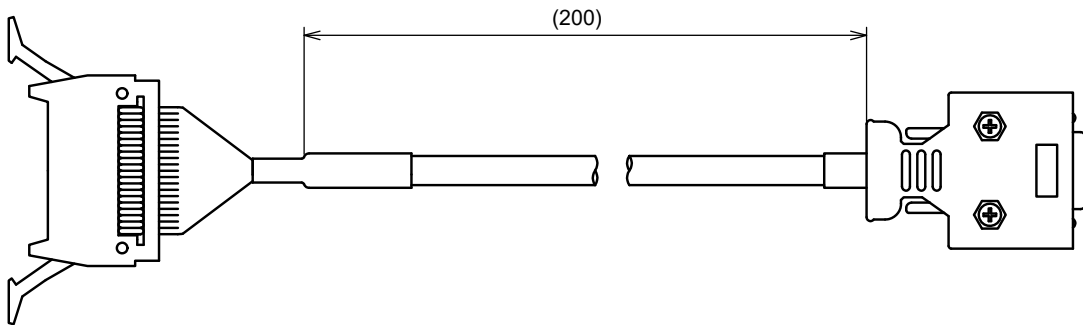

- Model F9Y4QA2

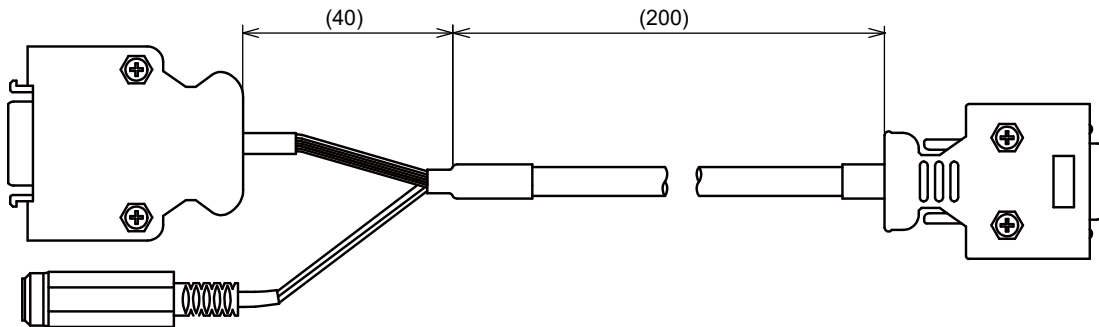

■ Dimensions of optional bracket

- Model 8F9Y4QB1 Mounting bracket for model F4Q (for 90 mm face-to-face length)

(Unit: mm)

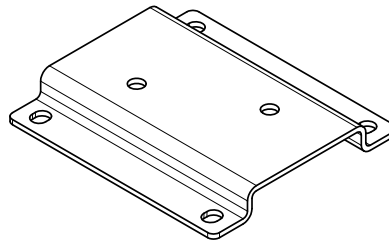
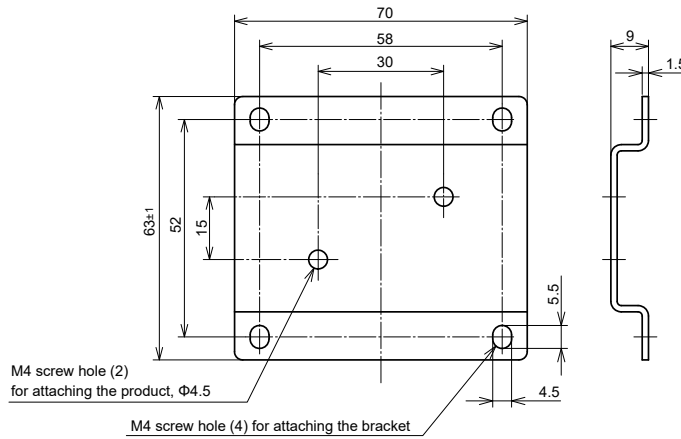

- Model 8F9Y4QB2 Mounting bracket for model F4Q (for 150 mm face-to-face length)

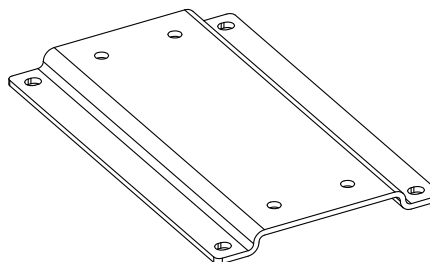
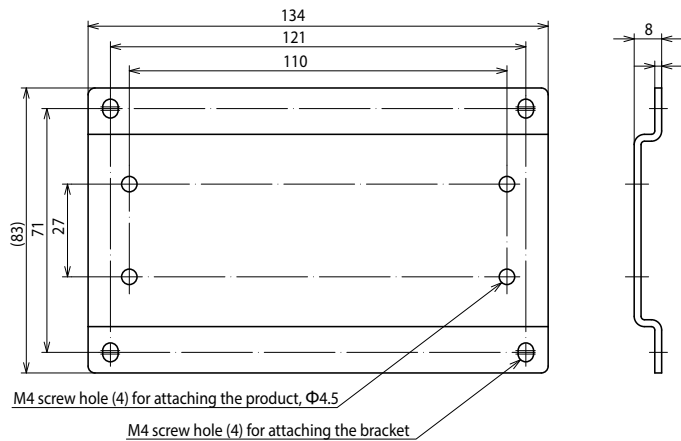

• Swagelok and VCR are trademarks of Swagelok Company.

Please read "Terms and Conditions" from the following URL before ordering and use.

<https://www.azbil.com/products/factory/order.html>

Specifications are subject to change without notice.

azbil

Azbil Corporation

Advanced Automation Company

1-12-2 Kawana, Fujisawa

Kanagawa 251-8522 Japan

URL: <https://www.azbil.com/>

1st edition: Mar. 2023
4th edition: Feb. 2024

No part of this publication may be reproduced or duplicated without the prior written permission of Azbil Corporation.